

ALLEN & HEATH



Remote Controller Getting Started Guide

IP6

- ⓘ Before starting please check www.allen-heath.com for the latest dLive firmware and documentation.

Limited One Year Manufacturer's Warranty

Allen & Heath warrants the Allen & Heath -branded hardware product and accessories contained in the original packaging ("**Allen & Heath Product**") against defects in materials and workmanship when used in accordance with Allen & Heath's user manuals, technical specifications and other Allen & Heath product published guidelines for a period of ONE (1) YEAR from the date of original purchase by the end-user purchaser ("**Warranty Period**").

This warranty does not apply to any non-Allen & Heath branded hardware products or any software, even if packaged or sold with Allen & Heath hardware.

Please refer to the licensing agreement accompanying the software for details of your rights with respect to the use of software/firmware ("EULA").

Details of the EULA, warranty policy and other useful information can be found on the Allen & Heath website: www.allen-heath.com/legal.

Repair or replacement under the terms of the warranty does not provide right to extension or renewal of the warranty period. Repair or direct replacement of the product under the terms of this warranty may be fulfilled with functionally equivalent service exchange units.

This warranty is not transferable. This warranty will be the purchaser's sole and exclusive remedy and neither Allen & Heath nor its approved service centres shall be liable for any incidental or consequential damages or breach of any express or implied warranty of this product.

Conditions Of Warranty

The equipment has not been subject to misuse either intended or accidental, neglect, or alteration other than as described in the User Guide or Service Manual, or approved by Allen & Heath.

Any necessary adjustment, alteration or repair has been carried out by an authorised Allen & Heath distributor or agent.

The defective unit is to be returned carriage prepaid to the place of purchase, an authorised Allen & Heath distributor or agent with proof of purchase. Please discuss this with the distributor or the agent before shipping. Units returned should be packed in the original carton to avoid transit damage.

DISCLAIMER: Allen & Heath shall not be liable for the loss of any saved/stored data in products that are either repaired or replaced.

Check with your Allen & Heath distributor or agent for any additional warranty information which may apply. If further assistance is required please contact Allen & Heath Ltd.

IMPORTANT - Read before starting

Safety instructions

Before starting, read the **Important Safety Instructions** printed on the sheet supplied with the equipment. For your own safety and that of the operator, technical crew and performers, follow all instructions and heed all warnings printed on the sheet and on the equipment panels.

System operating firmware

The function of the IP Remote Controller is determined by the firmware (operating software) that the mixing system runs. Firmware is updated regularly as new features are added and improvements made.

- ⓘ Check www.allen-heath.com for the latest version of mixer firmware. IP6 requires dLive firmware V1.30 or higher.

Software licence agreement

By using this Allen & Heath product and the software within it you agree to be bound by the terms of the relevant **End User Licence Agreement** (EULA), a copy of which can be found at www.allen-heath.com/legal. You agree to be bound by the terms of the EULA by installing, copying, or using the software.

Further information

Please refer to the **Allen & Heath website** for further information, knowledgebase and technical support. For more information on dLive setup and mixing functions please refer to the dLive Firmware Reference Guide available for download at www.allen-heath.com.

- ⓘ Check for the latest version of this Getting Started Guide.

You can also join our Allen & Heath Digital Community to share knowledge and information with other dLive users.

General precautions

- Protect the equipment from damage through liquid or dust contamination. Cover the equipment when it is not being used for a long period.
- If the equipment has been stored in sub-zero temperatures allow time for it to reach normal operating temperature before use at the venue. Recommended operating temperature is 0 to 35 degrees Celsius.
- Avoid using the equipment in extreme heat and direct sunlight. Make sure there is adequate air movement around the equipment.
- Clean the equipment with a soft brush and dry lint-free cloth. Do not use chemicals, abrasives or solvents.
- It is recommended that servicing is carried out only by an authorised Allen & Heath agent. Contact details for your local distributor can be found on the Allen & Heath website. Allen & Heath do not accept liability for damage caused by maintenance, repair or modification by unauthorised personnel.

Register your product

Register your product online at www.allen-heath.com/register.



This product complies with the European Electromagnetic Compatibility directive 2004/108/EC and the European Low Voltage directive 2006/95/EC.

Any changes or modifications to the product not approved by Allen & Heath could void the compliance of the product and therefore the user's authority to operate it.

IP6 Getting Started Guide

Copyright © 2016 Allen & Heath. All rights reserved.

ALLEN & HEATH

Allen & Heath Limited, Kernick Industrial Estate, Penryn, Cornwall, TR10 9LU, UK

<http://www.allen-heath.com>

Contents

IMPORTANT - Read before starting.....	3
1. Introduction.....	6
2. Mounting the Remote Controller	7
2.1 Plinth mount	7
3. Front Panel.....	8
4. Rear Panel.....	10
5. Connect and power up.....	11
5.1 Set up the unit Name and IP Address	11
5.2 dLive connection	12
5.3 Ethernet Switch	12
5.4 Programming the Remote Controller.....	13
6. Dimensions	14
7. Technical specs	15

Packed items

Check you have received the following:

- IP6 Remote Controller
- Getting Started Guide AP10352
- Safety Sheet
- 12V Power Supply

1. Introduction

The IP6 is part of the Allen & Heath IP Series of remote controllers. It interfaces with the dLive mixing system via standard TCP/IP Network connections and can therefore be networked with other controllers, computers and third party devices using a standard Ethernet infrastructure. It can be powered by an external 12V PSU or over Ethernet (PoE).

The IP6 controls and functions are programmed using a dLive Surface or dLive Director software for PC/Mac, and can suit a number of applications including:

- Personal Monitoring – The IP6 can be configured to control the Send levels, Pans and assignments of multiple channels to a specific mix on the dLive, for example for wireless IEM use, giving musicians the freedom to control their own monitor sound.
- Installation – The installer or system integrator can configure the IP6 to provide the degree of control needed by the day to day operator, for example the levels of microphones and music sources in a room.

2. Mounting the Remote Controller

The IP6 can be used free standing or mounted on a standard microphone stand thanks to the integrated 3/8" threaded hole.

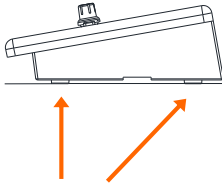

Non-slip feet fitted for shelf use

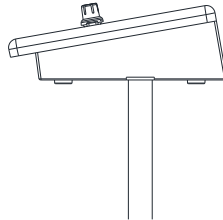

Top of mic stand with 3/8" thread

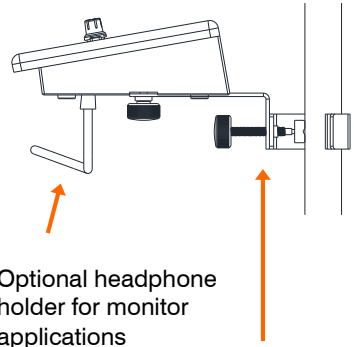

Optional headphone holder for monitor applications

Side of stand mount with optional bracket

The following accessories can be used to mount the IP6:

AB8999 Mic stand bracket

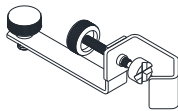

AB8705 Push in headphone holder

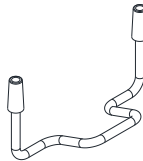

2.1 Plinth mount

Use the holes indicated below for 6B screws when mounting in a plinth, podium or furniture. Ensure adequate air flow around the unit.

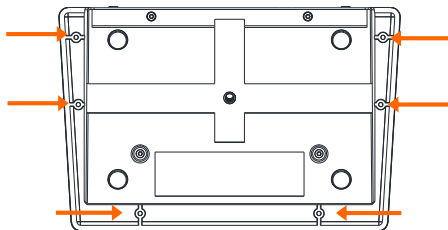

3. Front Panel

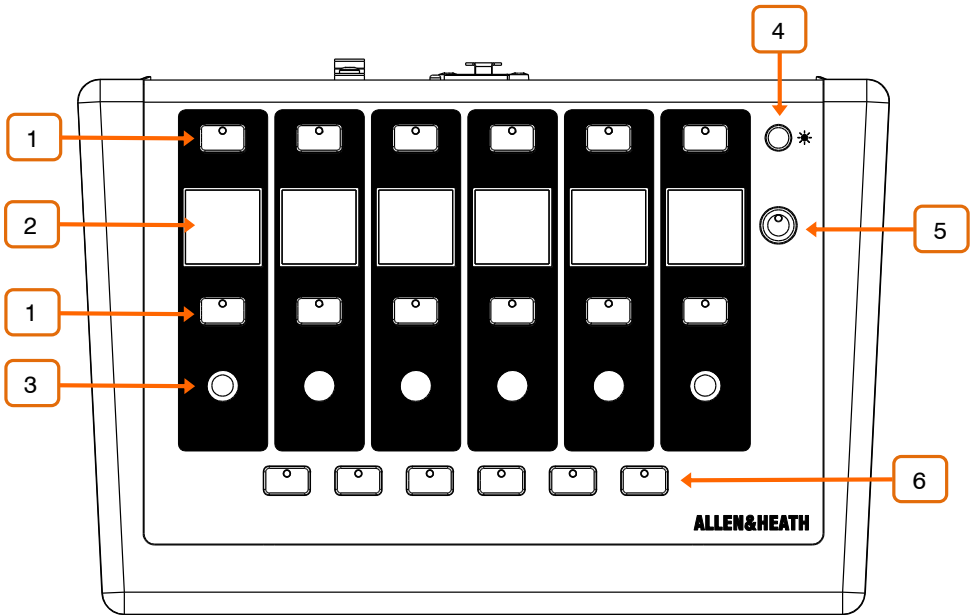

1 SoftKeys – 2 sets of 6x backlit assignable keys. Can be configured individually or as part of a vertical ‘Rotary Strip’. Available functions include Send On/Off, PAFL, Mute, Scene Recall, Tap Tempo, Talkback Assign, Custom MIDI.

2 LCD Displays – 6x colour displays providing information on the channels and on the function of the SoftKeys.

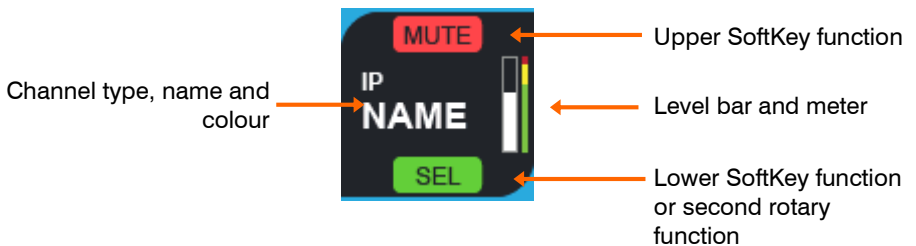

3

Rotary Encoders – 6x assignable dual function rotary controls. Can be configured individually or as part of a vertical 'Rotary Strip'. Push and turn a rotary to control its second function.

Available functions include Input Level, Mix Level, DCA Level, Aux Send Level, FX Send Level, Matrix Send Level, Pan, Custom MIDI.

4

Dimmer – Steps through different brightness presets for all displays and keys, for use in low light environments.

5

SoftKey (Alt View) – Assignable key. Can be configured to show alternative information on the LCD displays.

Other available functions include Send On/Off, PAFL, Mute, Scene Recall, Tap Tempo, Talkback Assign, Custom MIDI.

6

SoftKeys (Layers) – 6x additional, backlit assignable keys. Can be configured to change Layers on the Remote Controller. This allows up to 6 different sets of controls / channels instantaneously available at a press of a button. For example you can control the sends of 36 individual Inputs to a monitor mix, or set up the Layers to control the sound to 6 different zones in a venue.

Other available functions include Send On/Off, PAFL, Mute, Scene Recall, Tap Tempo, Talkback Assign, Custom MIDI.

4. Rear Panel

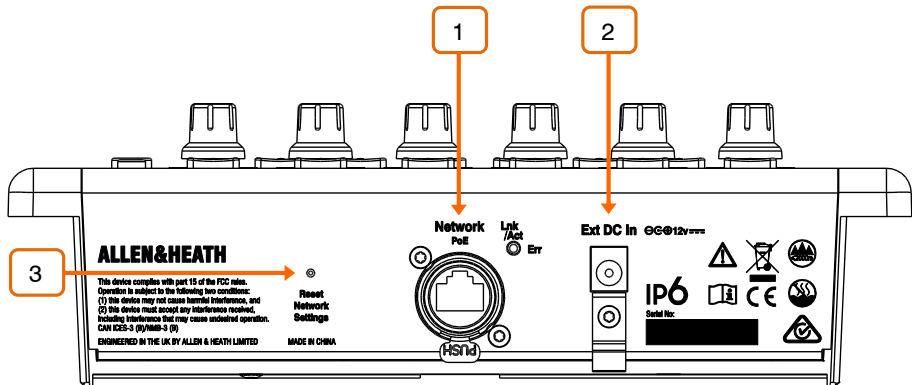

1

Network – Fast Ethernet, PoE compliant Network port for connection to the mixing system.

ⓘ The IP6 provides a locking Neutrik EtherCon socket to protect the connection. Use cables fitted with locking EtherCon for touring or rental applications.

ⓘ The maximum cable length is 100m. Use STP (shielded twisted pair) CAT5 or higher cables. Those with both foil and braided screens provide shielding from interference and are generally more rugged. Stranded core cables are less prone to damage when kinged or repeatedly coiled. Refer to www.allen-heath.com for a list of CAT5 cables available to order.

2

Ext DC In – External PSU input. Alternatively, the IP6 can be powered via the Network port when connected to a PoE switch.

A plastic P-clip cable clamp is provided to secure the DC cable.

ⓘ Only use the power supply provided in the box.

3

Reset Network Settings - A recessed switch lets you reset the network settings to factory default. To reset, insert a pointed object to press the switch whilst applying power to the unit, then release.

5. Connect and power up

5.1 Set up the unit Name and IP Address

When connecting multiple IP Remote Controllers to the same network, ensure each unit is set to a unique Name and IP Address beforehand. Alternatively you can enable DHCP on the Remote Controllers, provided a DHCP Server is present on the network and the DHCP range is compatible with the IP Address of the mixing system.

The factory default settings are as follows:

Unit Name	IP6
DHCP	Off
IP Address	192.168.1.72
Subnet Mask	255.255.255.0
Gateway	192.168.1.254

There are two ways of editing these settings:

Browser access – Connect a PC or Mac computer to the Network port of the IP6. Set your computer to a compatible, static IP Address, for example 192.168.1.100 with Subnet 255.255.255.0. Open a web browser and type the IP6 default IP Address **192.168.1.72** in the URL bar. This will give access to the unit network settings. Repeat the operation for each IP6 unit.

dLive software – Connect the IP6 to a dLive Network port. Use the Surface touchscreen interface or Director software to edit the IP6 network settings. Once applied, repeat the operation for each IP6 unit.

 Refer to the dLive Firmware Reference Guide available for download at www.allen-heath.com for more information.

5.2 dLive connection

Connect the IP6 to a MixRack or Surface Network port using a CAT5 cable up to 100m long.

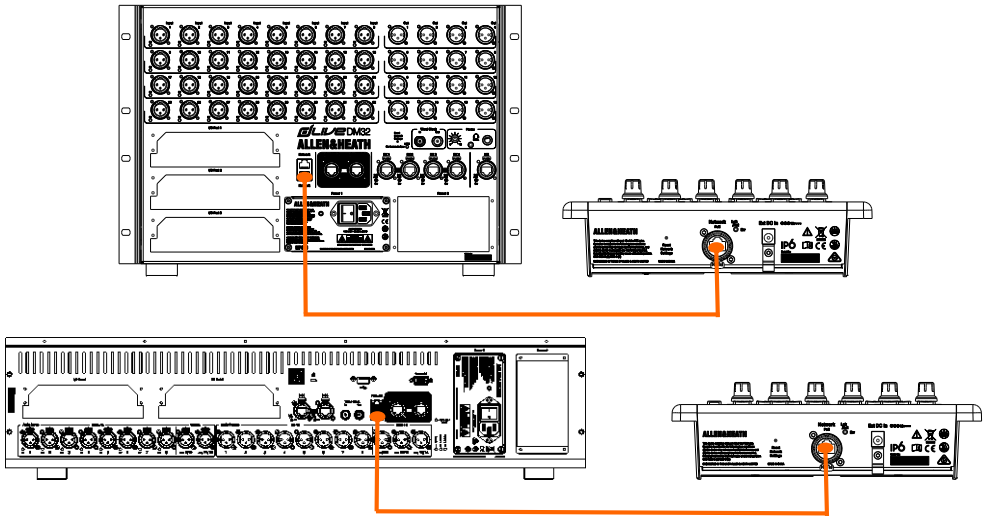

Power up the IP6 by plugging the external PSU into the DC In socket. The port Lnk/Err indicator flashes at a steady rate when the link is established. The unit Name and IP address are displayed on the LCD Displays for easy identification of the unit. After a few seconds the IP6 will display the assignments and functions if any have been set for the unit.

i If the firmware in a connected IP Remote Controller is not the same version as that in the dLive mixer, then the mixer will automatically update the IP firmware at power up.

5.3 Ethernet Switch

For parallel connection of multiple IP Remote Controllers you can use a standard Ethernet switch.

i For PoE (Power over Ethernet) either of the two standards 802.3af (15.4W at source) or 802.3at (25.5W at source) is suitable. Check that the overall power rating is enough to provide for all IP Remote Controllers you wish to connect (allow 10W per IP6 unit).

5.4 Programming the Remote Controller

Use the dLive Surface touchscreen interface or Director software to configure the Remote Controller. You can assign each key or rotary individually, or use one of the setup 'Wizards' on screen to get started quickly.

The IP6 can be set to link to either the dLive **MixRack** or the dLive **Surface**. This is regardless of the physical Network connection, for example the unit might be physically connected to the MixRack but set to link to the Surface. Linking to the MixRack provides an independent Remote Controller that can be used with or without Surface connection. Linking to the Surface adds the ability to assign extra functions to the IP6 SoftKeys such as **Sel** and **Mix**.

The functions and assignments of the IP6 are stored in the dLive Scenes. They are not stored locally on the Remote Controller.

 Refer to the dLive Firmware Reference Guide available for download at www.allen-heath.com for more information on configuring the Remote Controller.

6. Dimensions

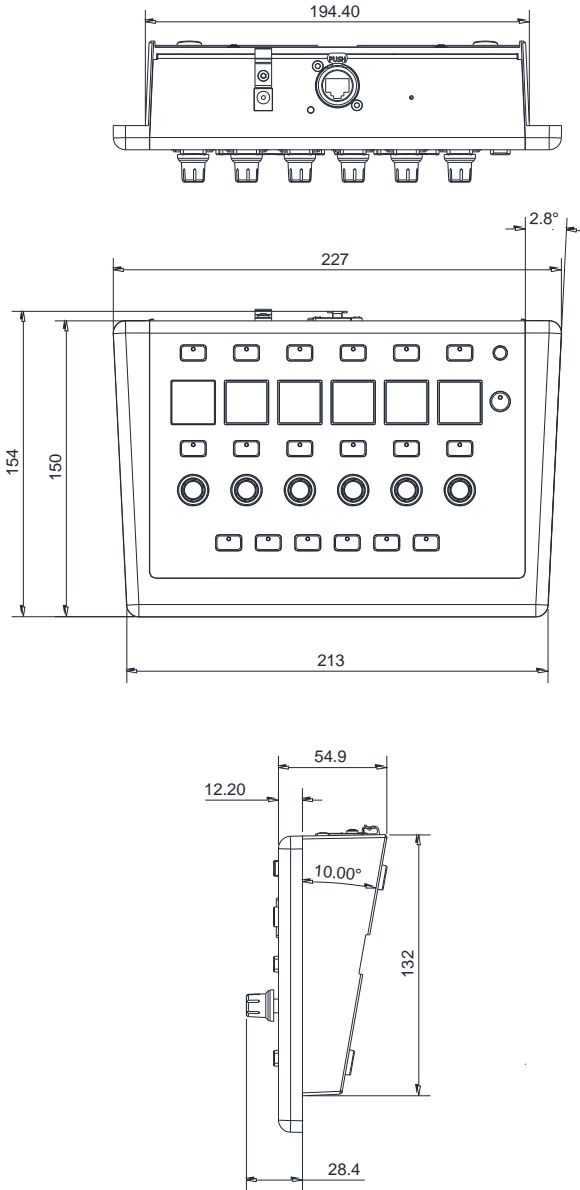

7. Technical specs

System

Network	Fast Ethernet 100MBps
Ext DC In	+12V, 2.5A
PoE	802.3af (15.4W at source)
Max power consumption	5W
Operating Temperature Range	0 deg C to 35 deg C (32 deg F to 95 deg F)

Dimensions and Weights

	Width x Depth x Height x Weight
IP6	227 x 150 x 55 mm x 1.5kg (3.3lbs)
IP6 (boxed)	300 x 330 x 170 mm x 1.6kg (3.5lbs)